

AIR PREPARATION UNITS

FILTER REGULATOR COMBINATION Series FRC1

Cat No FRC1 - 02 - C

FILTER REGULATOR COMBINATION - 1/8, 1/4, 3/8, 1/2, 3/4, 1"

Features

- Modular type
- Suitable for panel mounting
- Filter
 - Bronze filtering element.
 - Separator and shield for efficient moisture separation.
- Regulator
 - Diaphragm operated, relieving type.
 - Pressure compensated by balanced poppet.
 - Flow compensated in models FRC14, FRC15 & FRC17 (with venturi) for faster response.
 - Non raising ' Press to lock ' adjusting knob for locking at any set pressure.
- Steel bowl guard, bayonet type on FRC14, FRC15 & FRC17 models and threaded type on FRC13 model.
- Good flow and regulating characteristics.



Technical Specifications

Model	FRC 13	FRC 14	FRC 15	FRC 17	FRC 17
Medium	Compressed air				
Port size	NPT 1/8 (G1/8) NPT 1/4 (G1/4)	NPT 1/4 (G1/4) NPT 3/8 (G3/8)	NPT 1/4 (G1/4) NPT 3/8 (G3/8) NPT 1/2 (G1/2)	NPT 3/4 (G3/4)	NPT 1 (G1)
Pressure gauge port size	NPT 1/8 (G1/8)			NPT 1/4 (G1/4)	
Flow rate in scfm (NI / min) @	8.75 (250) 19.25 (550)	25.38 (725) 63 (1800)	31.68 (905) 80.5 (2300) 105 (3000)	210 (6000)	227.5 (6500)
Max supply pressure in psi (bar)	140 (10)				
Regulating Pressure Range in psi (bar) #	3 - 30 (0.2 - 2), 3 - 60 (0.2 - 4), 7 - 100 (0.5 - 7), 7 - 140 (0.5 - 10) (Standard)				
Ambient / Medium temperature	41° - 120° F (5° - 50° C)				
Filteration in microns #	1, 5, 25, 40 (standard), 50, 100				
Bowl capacity in ounce (ml) (at maximum condensate level)	0.30 (9)	1.08 (32)	1.48 (44)	5.58 (165)	5.58 (165)
Bowl material	Polycarbonate				
Installation	Vertical (as shown in the picture)				
Materials of construction	Aluminium, Bronze, Brass, Steel, Acetal, Polycarbonate, SS, Nitrile				
Optional accessories *	Clamp, Modular mounting kit, Pressure gauge				
Weight in lb (Kg)	0.66 (0.30)	1.276 (0.58)	2.794 (1.27)	4.61 (2.09)	4.52 (2.05)

@ Supply pressure 100 psi (7 bar), Set pressure 85 psi (6 bar), Pressure drop $\Delta p = 14.5$ psi (1bar) (For standard models)

For details see " How to order "

* For details refer optional accessories Cat No APA - 02 - C

Precautions

1. Note the direction of flow before installation and connect piping accordingly.
2. Flush pipings for dirt, dust, rust and other foreign particles.
3. Install in clean atmosphere.
4. Nipples of taper threads (R) to be used with teflon tape. Ensure teflon tape does not enter the unit during tightening. Nipples of straight threads (G) to be used with sealing washer.
5. Polycarbonate bowls may get damaged and possibly fail if exposed to synthetic oils, thinner, solvents, trichloroethylene kerosene or other aromatic hydrocarbons.

AIR PREPARATION UNITS

FILTER REGULATOR COMBINATION Series FRC1

Cat No FRC1 - 02 - C

Model FRC13

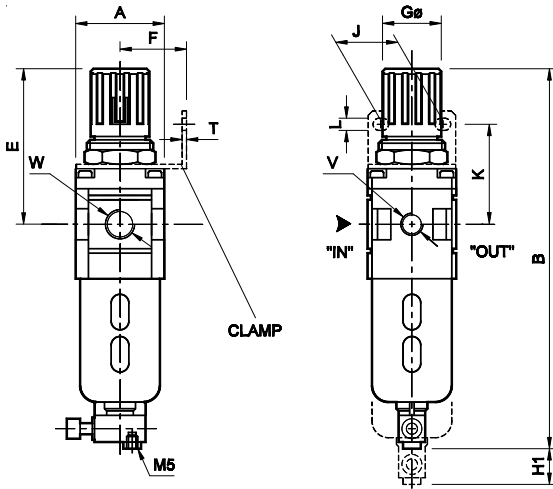

Model FRC14 & FRC15

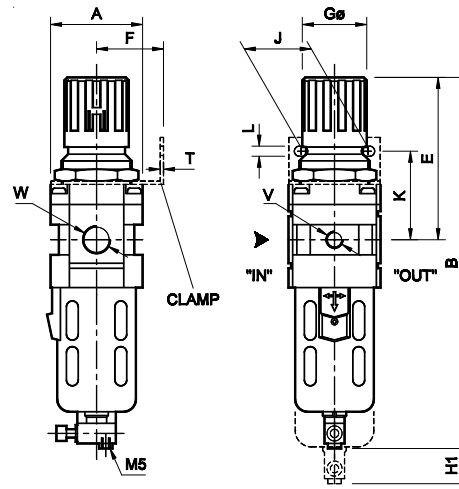

Model FRC17

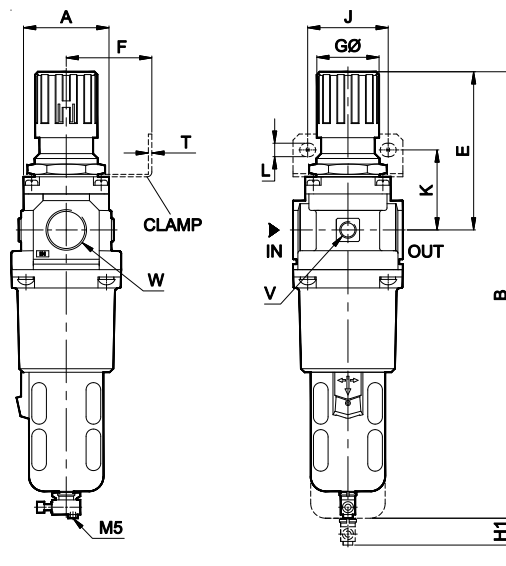

Model	W	V		A	B	E	F	K	GØ	J	L	T	H1
FRC13	NPT 1/8 (G1/8) NPT 1/4 (G1/4)	NPT 1/8 (G1/8)	Inch (mm)	SQ 1.575 (40)	6.69 (170)	2.68 (68)	1.181 (30)	1.772 (45)	1.102 (28)	1.102 (28)	0.216 (5.5)	0.079 (2)	1.968 (50)
FRC14	NPT 1/4 (G1/4) NPT 3/8 (G3/8)	NPT 1/8 (G1/8)	Inch (mm)	SQ 2.165 (55)	8.66 (220)	3.74 (95)	1.575 (40)	2.087 (53)	1.575 (40)	1.575 (40)	0.256 (6.5)	0.079 (2)	2.165 (55)
FRC15	NPT 1/4 (G1/4) NPT 3/8 (G3/8) NPT 1/2 (G1/2)	NPT 1/8 (G1/8)	Inch (mm)	SQ 2.756 (70)	11.02 (280)	4.92 (125)	1.968 (50)	2.441 (62)	2.008 (51)	2.165 (55)	0.335 (8.5)	0.079 (2)	3.15 (80)
FRC17	NPT 3/4 (G3/4)	NPT 1/4 (G1/4)	Inch (mm)	SQ 3.543 (90)	14.57 (370)	5.12 (130)	2.756 (70)	2.56 (65)	2.008 (51)	2.598 (66)	0.433 (11)	0.197 (5)	3.15 (80)
FRC17	NPT 1 (G1)	NPT 1/4 (G1/4)	Inch (mm)	SQ 3.543 (90)	14.57 (370)	5.12 (130)	2.756 (70)	2.56 (65)	2.008 (51)	2.598 (66)	0.433 (11)	0.197 (5)	3.15 (80)

For Details of Clamp see optional accessories Cat No APA - 02 - C

Pressure Setting

Pull the knob and adjust by turning the knob clockwise to increase the pressure. Push the knob back to its locked position.
(Turning the knob counter clockwise will reduce the pressure)

AIR PREPARATION UNITS

FILTER REGULATOR COMBINATION Series FRC1

Cat No FRC1 - 02 - C

Flow Graphs

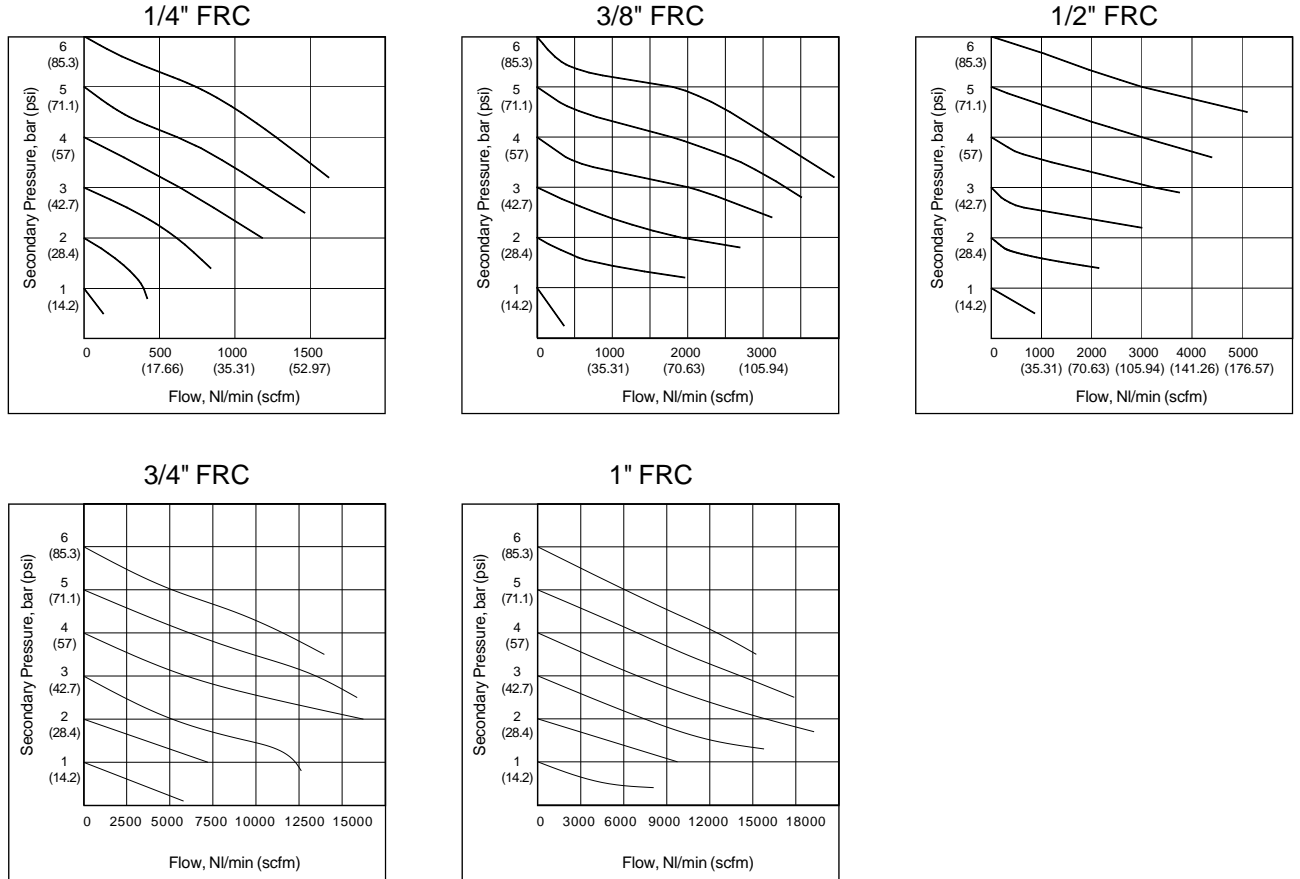

Flow graphs are for 40µm filtrations only

How to order

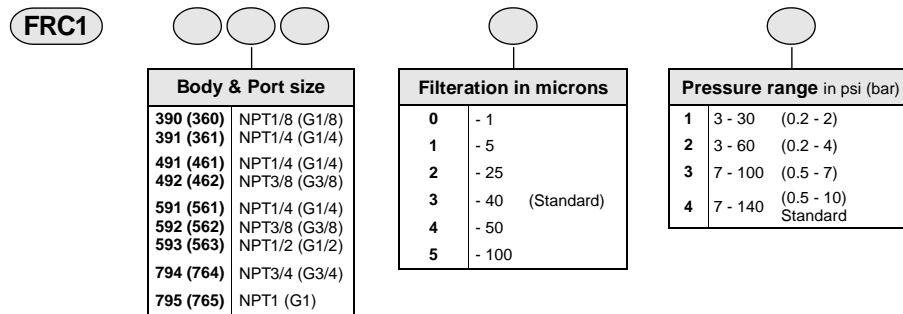

Ordering example :- Filter Regulator Combination - 3/8 size (with NPT 3/8 (G3/8) port) with 5 microns Filter and pressure range 7 - 100 psi: Ordering No: FRC 1492 (1462) 13.

If ordered as FRC 3/8 our standard model FRC 1492 (1462) 34, with 40 microns Filter and pressure range 7 -140 psi will be supplied.



- For safety instructions, please refer instruction manual IS - FRC1 - 2 - 01

Subject to change