

AIR PREPARATION UNITS FILTER WITH METAL BOWL Series F1M

Cat No F1M - 01 - C

FILTER WITH METAL BOWL - 1/4, 3/8, 1/2, 3/4, 1"

Features

- For higher pressure range above 10 bar
- Suitable for Modular mounting
- Aluminium bowl guard, bayonet type (3/4 and 1" only)
- Press type Manual drain for easy operation
- Suitable for Internal autodrain also
- Bronze filtering element
- Separator and shield for efficient moisture separation



Application

These type of filters are used for Chemical, Paintshops, Pharmaceutical, Foundry etc.

Technical Specifications

Model	F13...M	F14...M	F15...M	F17...M	F17...M
Medium	Compressed air				
Port size	G1/4	G3/8	G1/2	G3/4	G1
Flow rate (lts / min) [®]	800	2250	3500	5000	6500
Maximum supply pressure (bar)	20				
Ambient / Medium temperature	5° - 50° C				
Filteration # (µm)	1, 5, 25, 40 (standard), 50, 100				
Bowl capacity (ml) (at max. condensate level)	9	64	90	165	165
Bowl material	Aluminium				
Installation	Vertical (as in the picture)				
Materials of construction	Aluminium, Bronze, Steel, Acetal, SS, Nitrile				
Optional accessories *	Clamp, Modular mounting kit				
Weight (Kg)	0.20	0.45	0.85	1.47	1.43

[®] Supply pressure 6 bar , pressure drop $\Delta p = 0.3$ bar (For standard models).

For details see " How to order ".

* For details refer Optional accessories Cat No APA - 01 - C

Precautions

1. Note the direction of flow before installation and connect piping accordingly.
2. Flush pipings for dirt, dust, rust and other foreign particles.
3. Install in clean atmosphere.
4. Nipples of taper threads (R) to be used with teflon tape. Ensure teflon tape does not enter the unit during tightening.
Nipples of straight threads (G) to be used with sealing washer.

AIR PREPARATION UNITS FILTER WITH METAL BOWL Series F1M

Cat No F1M - 01 - C

Model F13...M

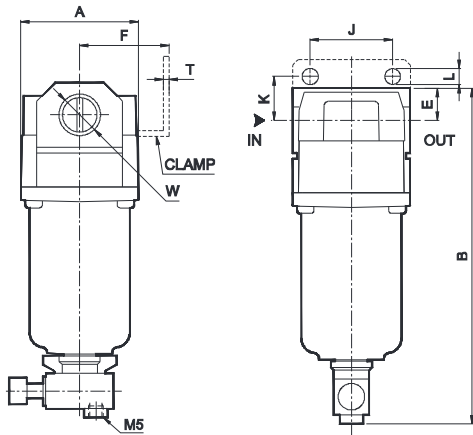

Model F14...M & F15...M

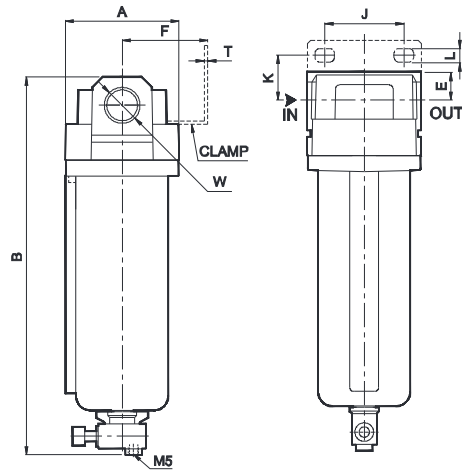

Model F17...-MM

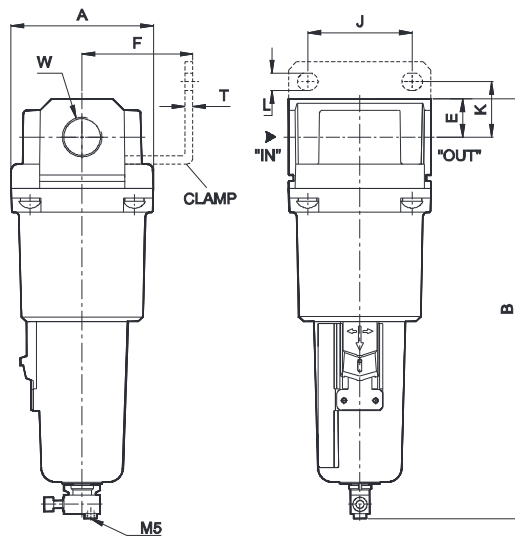

Model	W	A	B	E	K	F	J	L	T
F13...M	G1/4	SQ 40	115	11	15	30	28	5.5	2
F14...M	G3/8	SQ 55	188	14	25	40	40	6.5	2
F15...M	G1/2	SQ 70	224	18	25	50	55	8.5	2
F17...M	G3/4	SQ 90	265	24	35	70	66	11	5
F17...M	G1	SQ 90	265	24	35	70	66	11	5

For Details of Clamp see optional accessories Cat No APA - 01 - C

AIR PREPARATION UNITS

FILTER WITH METAL BOWL Series F1M

Cat No F1M - 01 - C

Flow Graphs

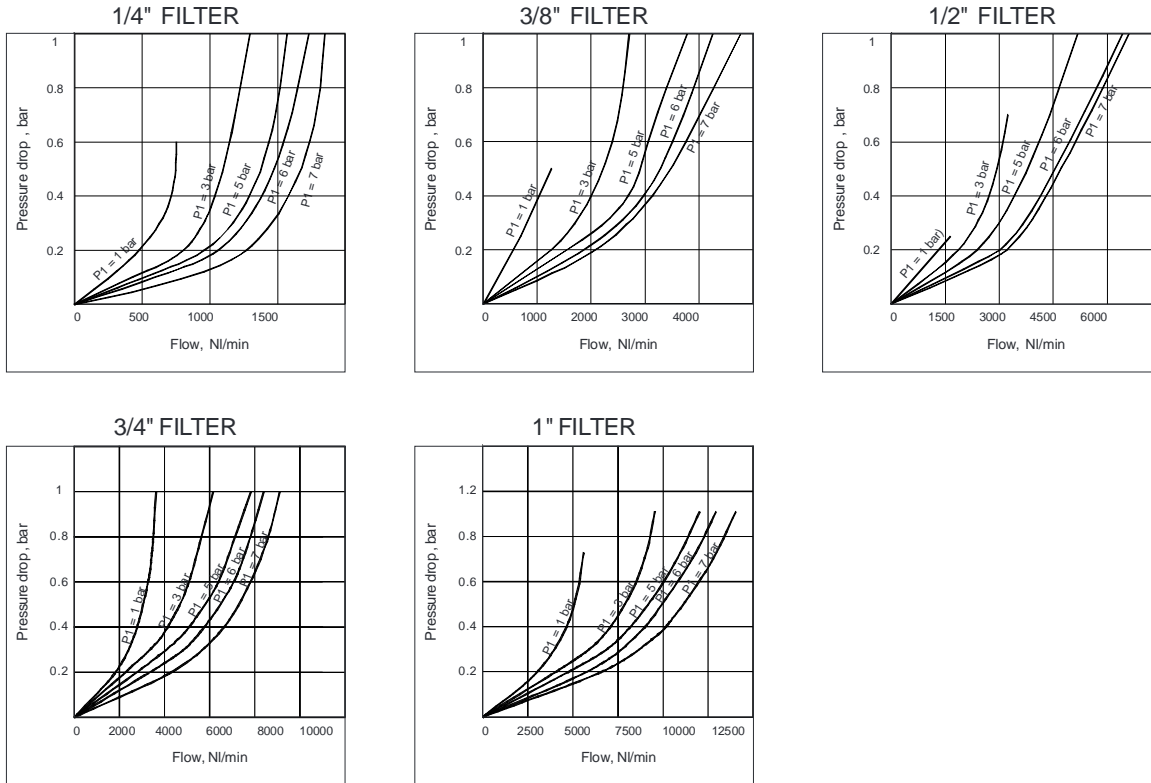

Flow graphs are for 40µm filtrations only

How to order

F1 ○ ○ ○ ○ ○

Body & Port size	
361	G1/4
462	G3/8
563	G1/2
764	G3/4
765	G1

Filtration in µm	
0	- 1
1	- 5
2	- 25
3	- 40 (Standard)
4	- 50
5	- 100

Metal bowl	
M	Without level indicator

Drain arrangement	
M	Manual drain (Standard)
A*	Auto drain

* Auto Drain - G3/8, G1/2, G3/4 & G1/2 model only

Ordering example :- Filter - 3/8 size (with 3/8" port) with 50µm and Metal bowl with Auto drain Ordering No: F14624 - MA.
If ordered as 3/8 " Filter with Metal bowl, our standard model F14623 - MM, with 40µm will be supplied .

Subject to change